

# POWER STATION



ENGLISH

## USER'S MANUAL

REV.01 05/2001



PROFESSIONAL FOUR CHANNELS  
HIGH POWER HEADPHONE AMPLIFIER

# SAFETY INSTRUCTIONS

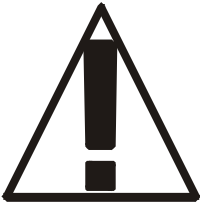

This symbol, wherever it appears, alerts you to important operating and maintenance instructions in the accompanying literature. Read the manual.

## **Detailed Safety and Operation Instructions:**

All the operation instructions and safety should be read before the machine is operated.

### **Follow instructions:**

All operation and user instructions should be followed by the user or the installer.

### **Retain Instructions:**

The safety and operating instructions should be carefully retained for future reference.

### **Heed Warnings:**

All warnings on the machine and in the operating instructions should be adhered to.

### **Water and Moisture:**

The machine should not be used near water or in place full of moisture.

### **Ventilation:**

The machine should be placed so that its location does not interfere with its proper ventilation. For example, the appliance should not be situated on a bed, carpet, or similar surface that may create an obstacle for the ventilation openings: or placed in a built-in installation, such as a bookcase or cabinet that may impede the flow of air around the machine.

### **Heat:**

The machine should be situated far away from heat sources such as heat registers, radiators, stoves, or other machines (including amplifiers) that produce heat.

### **Power Source:**

The machine should be connected to a power supply only of the type described in the operating instructions or as marked on the external power transformer.

### **Power-Cord Protection:**

Power supply cord should be routed so that it is not likely to be walked on or pinched by items placed upon or against it, paying particular attention to cords, power transformer and plugs and the point where they exit from the appliance.

### **Cleaning:**

The machine should be cleaned only as recommended by the manufacturer.

### **Non-use Periods:**

The external power transformer should be unplugged from the outlet when left unused for a medium or long period of time.

### **Object and Liquid Entry:**

Care should be taken so that objects do not fall and liquids are not spilled into the enclosure through openings, do not leave bottles or cans upon the unit.

### **Damages that Require Service:**

The unit should be serviced by qualified service personnel in the following cases:

1. The external power transformer, power supply cord or the plug has been damaged.
2. The enclosure of the unit has been damaged.
3. The unit has been exposed to water or moisture.
4. The unit does not appear to operate normally or exhibits a marked change in performance.
5. Objects have fallen, or liquid has been spilled into the unit.

### **Servicing:**

The user should not attempt to service the unit beyond what is described in the Operating Instructions. All other servicing should be referred to qualified and authorized service personnel.



# POWER STATION

## PROFESSIONAL FOUR CHANNELS HIGH POWER HEADPHONES AMPLIFIER



- ✓ Four totally independent stereo high-power amplifiers in XXL Half Rack Frame
- ✓ Fantastic audio quality even with extremely high volume levels
- ✓ Four Aux inputs provide up to four stereo independent mixes
- ✓ Double level control for each channel for separate Main In and Aux in control
- ✓ Mono/stereo switch for each channel for greater flexibility
- ✓ Possibility to parallel several headphone sets
- ✓ Servo-balanced Main and Aux inputs to avoid noise problems
- ✓ Ultra-low noise 4580 audio op-amps for outstanding sound performance
- ✓ High-quality potentiometers and illuminated switches
- ✓ High-quality, low tolerance components for highest results.
- ✓ Full Aluminium rugged construction ensures long life and durability
- ✓ External power supply design for professional applications
- ✓ Battery use possibility with external dedicated battery pack

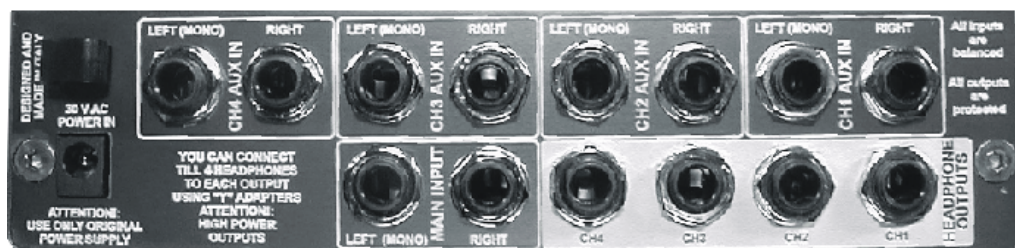

# TABLE OF CONTENT

<b>1. INTRODUCTION</b>	<b>p. 4</b>
1.1 High Technology	p. 4
<b>2. THE DESIGN</b>	<b>p. 4</b>
2.1 The MAIN input	p. 4
2.2 The additional AUX input	p. 4
2.3 The mono Switch	p. 5
2.4 The power output	p. 5
<b>3. INSTALLATION</b>	<b>p. 5</b>
3.1 Packaging	p. 5
3.2 Rack mounting	p. 5
3.3 Mains voltage	p. 5
3.4 Audio connections	p. 6
<i>Fig. 3.1: Different Connector Types and Wiring</i>	<i>p. 6</i>
<i>Fig. 3.2: Headphones connector</i>	<i>p. 7</i>
<b>4. CONTROLS</b>	<b>p. 8</b>
<i>Fig.4.1 Front panel controls</i>	<i>p. 8</i>
<i>Fig. 4.2 Back panel connections</i>	<i>p. 9</i>
<b>5. APPLICATIONS</b>	<b>p. 10</b>
5.1 Using the AUX IN input	p. 10
5.2 Using the MAIN IN input	p. 10
<i>Fig.5.1 Studio playback application</i>	<i>p. 11</i>
<i>Fig.5.2 Live /Studio monitor System</i>	<i>p. 11</i>
5.3 MONO MAIN function	p. 12
5.4 Connecting more headphones	p. 12
<b>6. TECHNICAL SPECIFICATIONS</b>	<b>p. 13</b>



## 6. INTRODUCTION

In purchasing the XXL POWER STATION, you have acquired a professional headphone power amplifier of the high-end class which meets all the demands and requirements of studio and live works. In fact it is an extremely efficient and universal headphone amplifier that can drive headphones from 64 to 600 ohm and more. It has been designed above all to deliver great power and to be a reference unit for the sonic evaluation of the final mix. It is also a powerful distribution monitor amplifier for musicians in the studio or in the stage.

### 1.1 High Technology

Our experience in the field of professional studios drove us to design the POWER STATION, an incredible small size four channels professional Headphone power amplifier that is able to give answer to all the demands in Studio, Live, broadcast and TV applications. All the electronics is assembled directly on PCB with no wires use, it means less possibility of malfunction. All the internal IC are 4580, ultra High quality Operational Amplifier that allow high current output with very low noise threshold. All the output are protected in order to guarantee safe operating conditions in every situation. All the inputs are balanced, in this way you can have the best matching conditions with the other machines. The choice of having the external power supply ensure professional features with minimum noise, and allow you to drive the power station also with an external optional battery pack to use the unit also without the presence of main power AC.

## WARNING!

**It should be pointed out, that extreme output levels may damage your ears and/or your headphone set. Turn down the LEVEL controls before you switch on the unit.**

## 7. THE DESIGN

### 2.1 The MAIN input

A Stereo MAIN input allow you to send simultaneously a mono or stereo signal to all the four amplifier . The main input has a balanced circuit that allow you to connect directly both balanced or unbalanced signals. The PWER STATION has independent level controls for each amplifier.

### 2.2 The additional AUX input

Each of the four stereo amplifiers is equipped with an independent AUX input. Also the Aux inputs have a balanced circuit that allow you to connect directly both balanced or unbalanced signals. The Aux input allows for adding a further audio signal to the main signal. The musician can therefore control the volume of his/her own instrument in the master playback signal as desired. This built-in mix function supersedes the external monitor mixer required up to now. For the same reason you can add a click signal on



the master playback signal and you can manage both the levels of the two sources as you desire.

### **2.3 The mono Switch.**

Each of the four Channels is equipped with a Mono function Switch that allow you to decide if you need to work with a mono or a stereo signal. In this way if you choose the possibility you can mix more than two different signals and listen to them in both your ears. When a MONO Switch of a channel is pushed down this means that this channel is set to mono mode and the red led is on.

### **2.4 The power output**

Each channel has a stereo power output on a standard stereo Jack. This power output is full protected and is possible to connect on it more than one headphones set just using stereo “y” adapters.

## **8. INSTALLATION**

### **3.1 Packaging**

XXL carefully pack in the factory all its units and the packaging was designed to protect the unit from rough handling. Nevertheless, we recommend that you carefully examine the packaging and its contents for any signs of physical damage, which may have occurred in transit.

## **ATTENTION!**

**If the unit is damaged, please do not return it to us, but notify your dealer and the shipping company immediately, otherwise claims for damage or replacement may not be granted. Shipping claims must be made by the consignee.**

### **3.2 Rack mounting**

The POWER STATION fits into one new standard “half rack” unit of space (1 3/4"). Please allow at least an additional 4" depth for the connectors on the back panel. Be sure that there is enough air space around the unit for cooling and please do not place the unit on high temperature devices such as power amplifiers to avoid overheating. It is also possible to fit the POWER STATION into one standard rack unit of space (1 3/4") using the optional RK100 rack adapter that you can buy from your Dealer.

### **3.3 Mains voltage**

Before you connect your unit to the mains AC socket, please make sure that your local voltage matches the voltage required by the external power supply of your unit! In case that the label of your Unit transformer require a voltage different from the one that you have in your Country do not connect it to mains and contact your Dealer.





### 3.4 Audio connections

The MAIN and the AUX inputs on the POWER STATION are fully balanced. If possible, connect the unit to other devices in a balanced configuration to allow for maximum interference immunity.

**Please ensure that only qualified persons install and operate the POWER STATION. During installation and operation the user must have sufficient electrical contact to earth. Electro-static charges might affect the operation of the POWER STATION!**

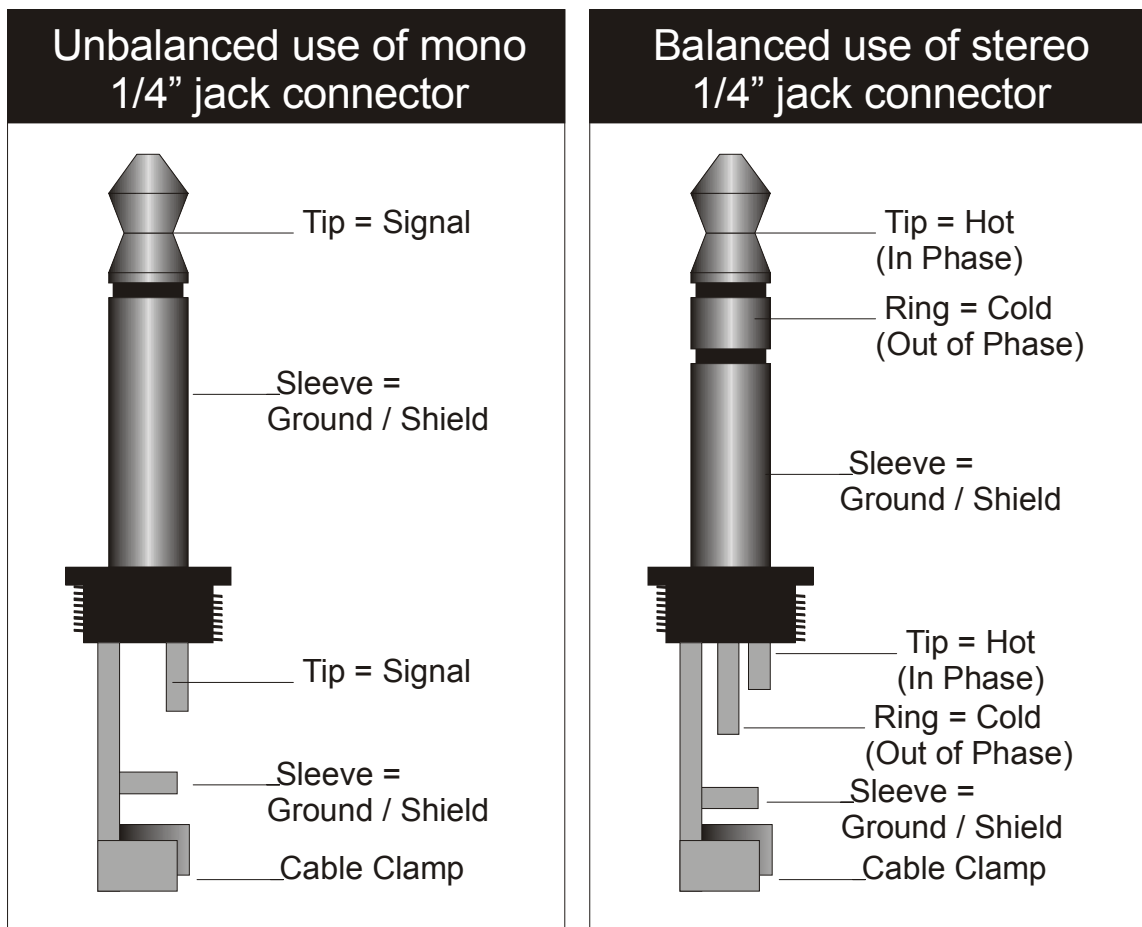

**Fig. 3.1: Different Connector Types and Wiring**



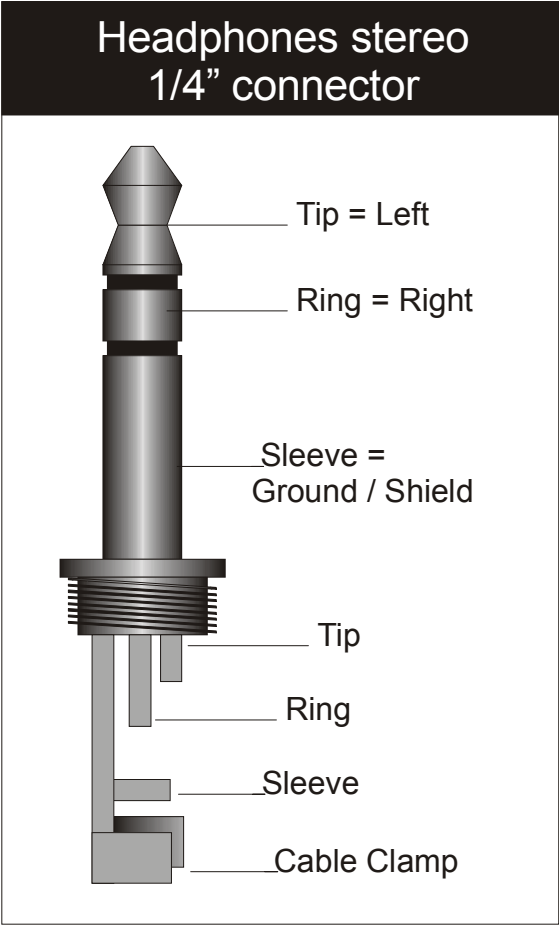
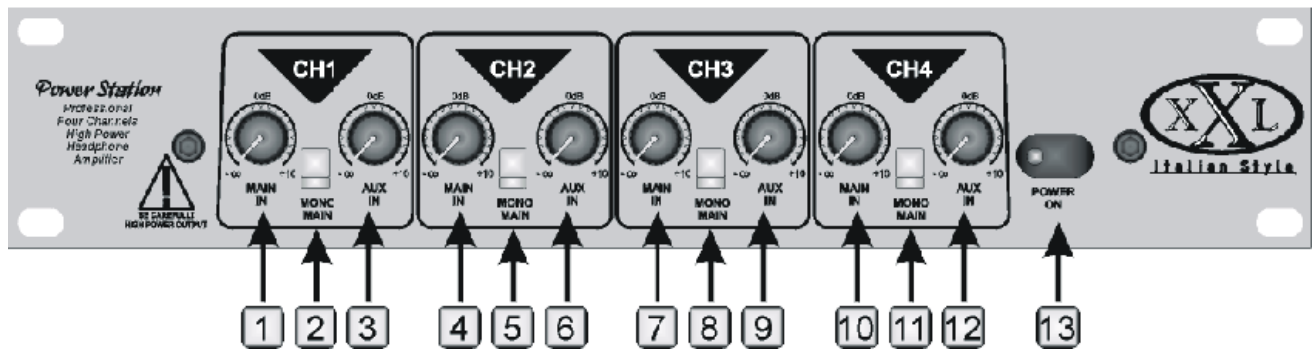

**Fig. 3.2: Headphones connector**





## 9. CONTROLS



**Fig.4.1 Front panel controls**

- 1) The CH1 MAIN IN control adjusts the level of the input signal inserted via the rear panel MAIN INPUT connectors on the CH1 amplifier.
- 2) With the CH1 MONO switch the amplifier can be switched between stereo to mono mode, and vice versa.
- 3) The CH1 AUX IN control adjusts the level of the input signal inserted via the rear panel CH1 AUX INPUT connectors on the CH1 amplifier.
- 4) The CH2 MAIN IN control adjusts the level of the input signal inserted via the rear panel MAIN INPUT connectors on the CH2 amplifier.
- 5) With the CH2 MONO switch the amplifier can be switched between stereo to mono mode, and vice versa.
- 6) The CH2 AUX IN control adjusts the level of the input signal inserted via the rear panel CH2 AUX INPUT connectors on the CH2 amplifier.
- 7) The CH3 MAIN IN control adjusts the level of the input signal inserted via the rear panel MAIN INPUT connectors on the CH3 amplifier.
- 8) With the CH3 MONO switch the amplifier can be switched between stereo to mono mode, and vice versa.
- 9) The CH3 AUX IN control adjusts the level of the input signal inserted via the rear panel CH3 AUX INPUT connectors on the CH3 amplifier.
- 10) The CH4 MAIN IN control adjusts the level of the input signal inserted via the rear panel MAIN INPUT connectors on the CH4 amplifier.
- 11) With the CH4 MONO switch the amplifier can be switched between stereo to mono mode, and vice versa.
- 12) The CH4 AUX IN control adjusts the level of the input signal inserted via the rear panel CH4 AUX INPUT connectors on the CH4 amplifier.
- 13) The POWER ON switch is the main power switch and allow you to switch on /off the device.

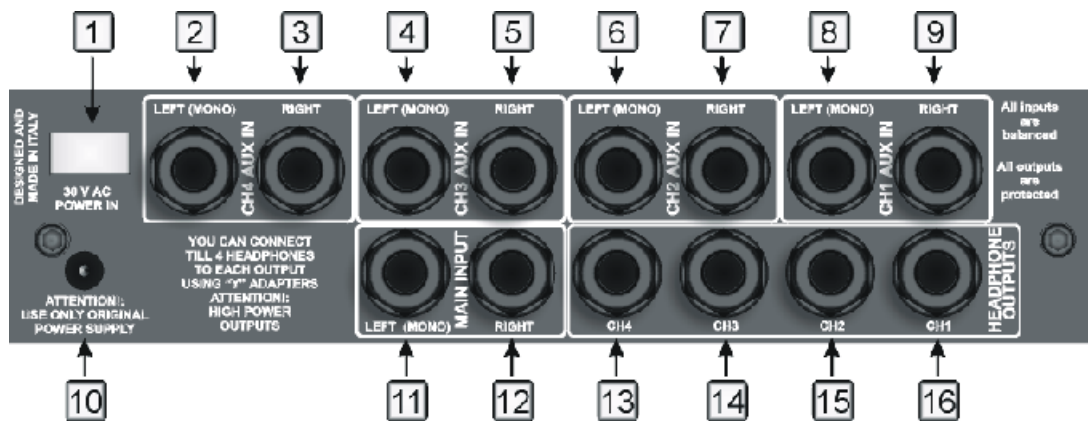

**Fig. 4.2 Back panel connections**

- 1) Power Supply cable holder.
- 2) CH4 LEFT (MONO) AUX INPUT. Use as auxiliary left or mono audio input for CH4, connect balanced or unbalanced standard phone jack.
- 3) CH4 RIGHT AUX INPUT. Use as auxiliary right audio input for CH4, connect balanced or unbalanced standard phone jack.
- 4) CH3 LEFT (MONO) AUX INPUT. Use as auxiliary left or mono audio input for CH3, connect balanced or unbalanced standard phone jack.
- 5) CH3 RIGHT AUX INPUT. Use as auxiliary right audio input for CH3, connect balanced or unbalanced standard phone jack.
- 6) CH2 LEFT (MONO) AUX INPUT. Use as auxiliary left or mono audio input for CH2, connect balanced or unbalanced standard phone jack.
- 7) CH2 RIGHT AUX INPUT. Use as auxiliary right audio input for CH2, connect balanced or unbalanced standard phone jack.
- 8) CH1 LEFT (MONO) AUX INPUT. Use as auxiliary left or mono audio input for CH1, connect balanced or unbalanced standard phone jack.
- 9) CH1 RIGHT AUX INPUT. Use as auxiliary right audio input for CH1, connect balanced or unbalanced standard phone jack.
- 10) MAIN POWER SUPPLY SOCKET. Use only original power supply. Read carefully the SAFETY INSTRUCTIONS before connecting the device.
- 11) LEFT (MONO) MAIN INPUT. Use as main left or mono audio input for all the channels, connect balanced or unbalanced standard phone jack.
- 12) RIGHT MAIN INPUT. Use as main right audio input for all the channels, connect balanced or unbalanced standard phone jack.
- 13) HADPHONE OUT 4. Use to connect your Stereo Headphone device using a standard phone jack.
- 14) HADPHONE OUT 3. Use to connect your Stereo Headphone device using a standard phone jack.
- 15) HADPHONE OUT 2. Use to connect your Stereo Headphone device using a standard phone jack.
- 16) HADPHONE OUT 1. Use to connect your Stereo Headphone device using a standard phone jack.

## 5. APPLICATIONS

In the XXL POWER STATION it is possible to use the Main input or the Channel AUX input to drive each channel. It is also possible to use both of them together in order to mix two different signals (for example a monitor mix with a click) and to feed with this mix your own headphone amplifier.

### 5.1 Using the AUX IN input

The AUX IN inputs are used to add an additional input signal to the master signal, with the corresponding AUX IN level control it is possible to determine the volume of the AUX IN input signal.

Example: suppose a vocalist wants to record a vocal track that is to be added to already existing instrumental tracks or a drummer that need a click signal added to the monitoring track. In these case The playback signal is inserted via the MAIN inputs, and the pre-amplified vocal signal (or the click) is applied to the AUX connector. Now, using both the MAIN IN and the AUX IN level controls of the desired channel it is possible to determine the right level of the two signals in the headphone output.

Thanks to the four independent channels of the POWER STATION, four individual mixes for four musicians can be achieved. In this case it is possible to connect four independent sources (for example four aux outputs of a mixer) one to each channel AUX IN input of the POWER STATION.

### 5.2 Using the MAIN IN input

The POWER STATION can also be used to drive four independent headphones driven by the same input signal (for example you can feed it from the main output of a mixer or from an aux output). In this case



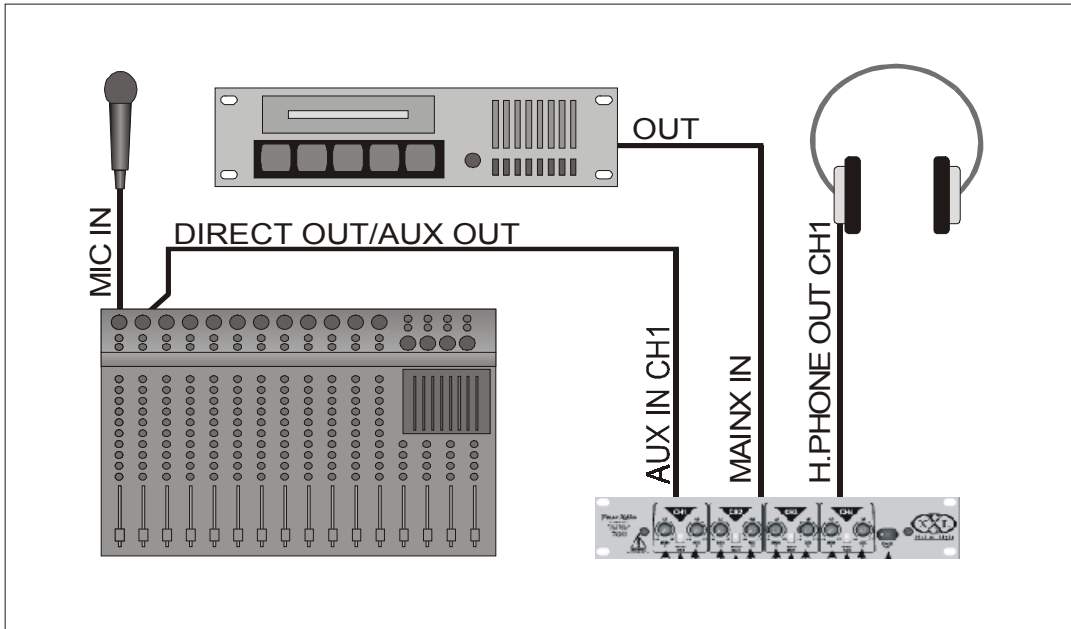

**Fig.5.1 Studio playback application**

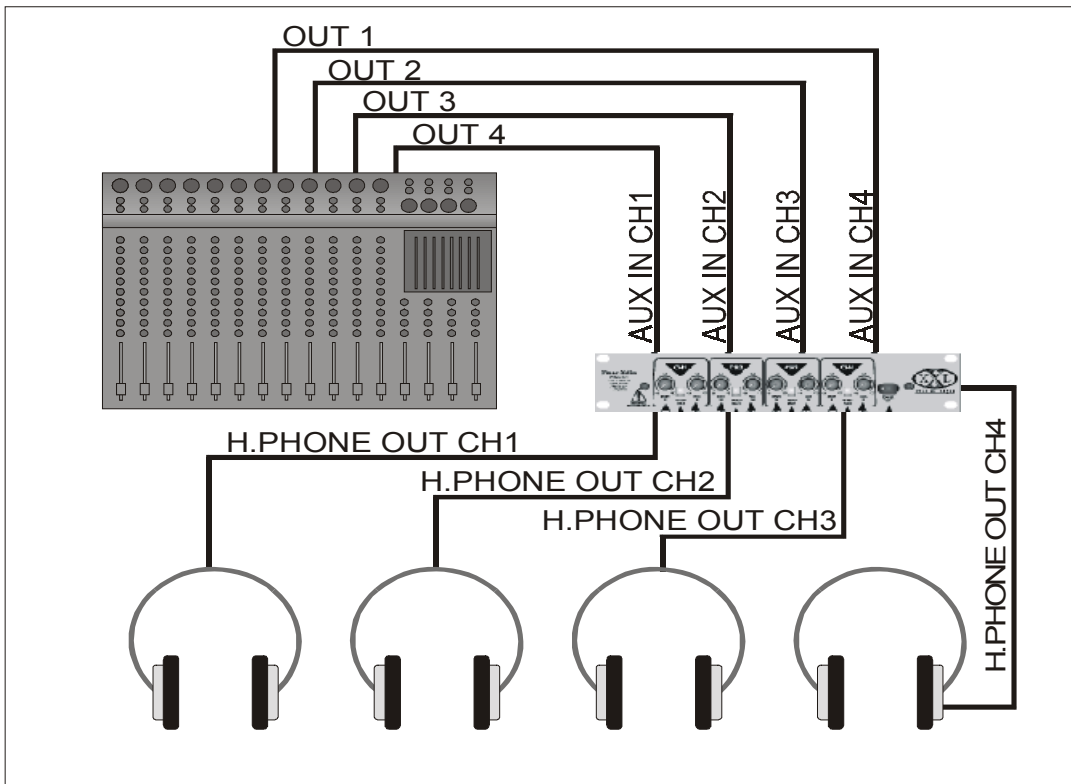

**Fig.5.2 Live /Studio monitor System**



### **5.3 MONO MAIN function.**

Each channel of the POWER STATION has a MONO MAIN switch that allow, when pressed, to have a mono signal in both left and right output of each channel also if there are connected two different sources to the left and right input jacks of the MAIN IN. In this way, for example, is possible to add directly a mono audio signal to a mono click signal leaving free the AUX IN input of all the channels. So that is possible to connect a mono or a stereo signal to each AUX IN input of the channels and is possible to mix it (stereo or mono) with the MAIN IN mix.

### **5.4 Connecting more headphones**

All of the four stereo amplifiers feature one rear panel headphone output connector. Multiple headphones can be connected per channel, on condition that the resulting connection impedance does not fall below 32 Ohms. As the power amplifiers are resistant to temporary short circuits, an impedance drop will not cause any damage, however, it can affect the quality of reproduction, in terms of long-term damage and distortion. If you wish to connect more than one headphones per amplifier, it is possible to use a split box or appropriate "Y" adapters. Remember that each time that you connect an additional headphone to a channel you reduce the resulting impedance. Consider that if you connect in parallel mode two headphones with the same impedance the resulting impedance will be half the impedance of each headphone.



## 6. TECHNICAL SPECIFICATIONS

### AUDIO INPUT

#### MAIN input

Connectors 1/4" jack  
Type RF filtered, servo balanced input  
Impedance 20 kOhms balanced, 10 kOhms unbalanced  
Max. input level +22 dBu balanced and unbalanced (unity gain)  
CMRR typ. 40 dB, >55 dB @ 1 kHz

#### AUX IN input

Connectors 1/4" jack  
Type RF filtered, servo balanced input  
Impedance 20 kOhms balanced, 10 kOhms unbalanced  
Max. input level +22 dBu unbalanced (unity gain)  
CMRR typ. 40 dB, >55 dB @ 1 kHz

### SYSTEM SPECIFICATIONS

Frequency response 10 Hz to 100 kHz, +/- 3 dB  
S/N ratio >105 dB referred to max out, unweighted, 22 Hz to 22 kHz  
THD 0.005 % typ. @ +4 dBu, 1 kHz, Gain 1  
POWER AMPLIFIER  
Max. output power +22 dBu  
Min. output impedance 32Ohms  
Max. gain +44 dB

### FUNCTION CONTROLS

MAIN IN Input level variable  
AUX IN Input level variable

### FUNCTION SWITCHES

Mono switches channel MAIN IN to mono

### POWER SUPPLY

External dedicated power supply  
Battery pack (optional)

### PHYSICAL

Dimension 44 mm X 240 mm X 120 mm  
Net weight approx. 1 kg  
Shipping weight approx. 1.5 kg



**NOTES:**





**XXL** Is a trade mark of HP Sound Equipment srl  
via Faentina 169/7 50010 Caldine Florence - ITALY  
Tel +39 0555040002 Fax +39 0555040460  
Web site: [www.x-x-l.it](http://www.x-x-l.it) E-mail: [info@x-x-l.it](mailto:info@x-x-l.it)

*New materials and design refinements are introduced into existing products without previous notice.  
Present XXL Systems may differ in some respects from those presented in this brochure.*

15 - POWER STATION  
MANUAL



USER'S